

You don't have to just flowback anymore, with Revo Advanced Well Testing Services you can flowSMART™



Revo Can Assist

Revo understands the unprecedented challenges that current market conditions present. Oil and gas operators need to **lower costs** and **maximize recovery**.

"Finally I can continuously monitor flowback data and know exactly how my well is performing anytime from anywhere. Revo's well testing service is efficient, safe, and convenient."

KIRK DESHOTELS
COMPLETIONS & PRODUCTION MANAGER
PETROEDGE ENERGY IV LLC



Real time well surveillance and performance management on your PC or mobile device

FlowSmart™ Solution Set

Automated Well Testing System

Better separation efficiency reduces oil lost as skim and water counted in BS&W resulting in higher revenue from oil sales and less rejected loads

Fully electric to help achieve emission targets

Reduced manning requirements to lower cost

Data on Demand

Complete operational transparency with data on demand and visualizations to give you full oversight of well testing operations

Unique Reservoir Analytics

Real time diagnostic evaluation and choke management workflow to improve well performance and help maximize asset value

Minimize completion damage by reducing/eliminating any sand production

Safe and Efficient Operations with Reduced Environmental Exposure

Digital wellhead measurements automate the initiation of alarms and isolation processes

Separator Automated Control System with LEL & H2S sensors, programmable level and pressure detection

All welded spools, no threaded connections



FlowSmart™ Solution Set helps reduce carbon emissions

SMART FLOWBACK

Please contact us for more detailed information

◆ INFO@REVOTEST.COM
◆ 832.672.4590
◆ 650 N Sam Houston Pkwy E Suite 313 Houston, Texas



Next Generation Digital Flow Testing System

Liquid Level Control

Automated vessel fluid level control provides constant levels to improve liquid measurement accuracy

Liquid Rate Measurement

Coriolis meters provide the highest measurement accuracy for both oil and water

Command and Control Center

Continuous sensor monitoring improves efficiency and reduces safety and environmental hazards

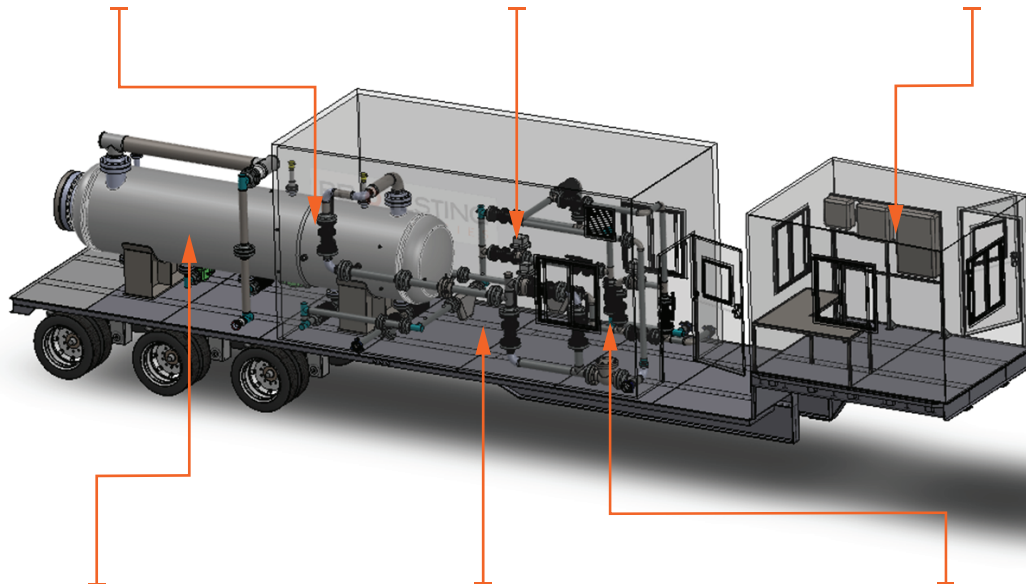

Separation Efficiency

Enhanced inlet for velocity reduction; internal liquid coalescing increases separation efficiency

Gas Rate Measurement

Gas conditioning plates utilized to improve measurement accuracy

Electric Control

Fully electric control system reduces gas venting and eliminates emissions

Additional Benefits to E&P Customers

- Reduced hazard exposure using remote operation capability
- Higher quality data, enabling advanced analytics
- Increased oil sales with proprietary separation technology
- Reduced emissions with fully electric control system
- Data-on-demand with Revo Performance Management software

Revo is setting a new standard for flow testing services. Discover more details online:

RevoTestingTech.com



SMART
FLOWBACK

Please contact us for more detailed information

- ◆ INFO@REVOTEST.COM
- ◆ 832.672.4590
- ◆ 650 N Sam Houston Pkwy E Suite 313 Houston, Texas